

Disclaimer: Drawings produced by DANOSA UK should be considered non-scalable and for illustrative purposes only. Issued design principals form instructions for the installation of DANOSA UK materials only and should be considered as part of an overall design rather than in isolation. Product 'Technical Datasheets' are available for all DANOSA UK products and should be consulted in conjunction with all issued DANOSA UK installation instructions. Drawings are subject to copyright and should not be reproduced without permission.

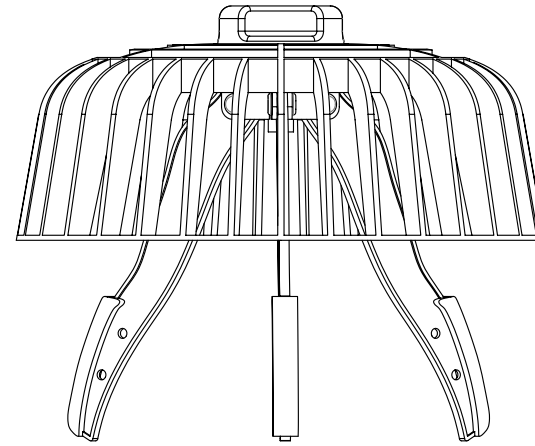

Drawing Notes:

Structural substrates shown in this drawing are for illustrative purposes only.

All DANOPOL membrane hot-air welds should be between 30-40mm. Overlaps should provide sufficient cover to accommodate this requirement.

Rainwater outlets should be supplied and installed with a suitable outlet guard as determined by the DANOSA flow rate calculation.

DANOSA rainwater outlets are supplied with a 400mm spigot.

Note A:
DANOSA recommends a bead of DANOSEAL sealant (or similar method) to create an air-seal around the penetration. This recommendation should be followed in conjunction with any internal air-sealing strategy.

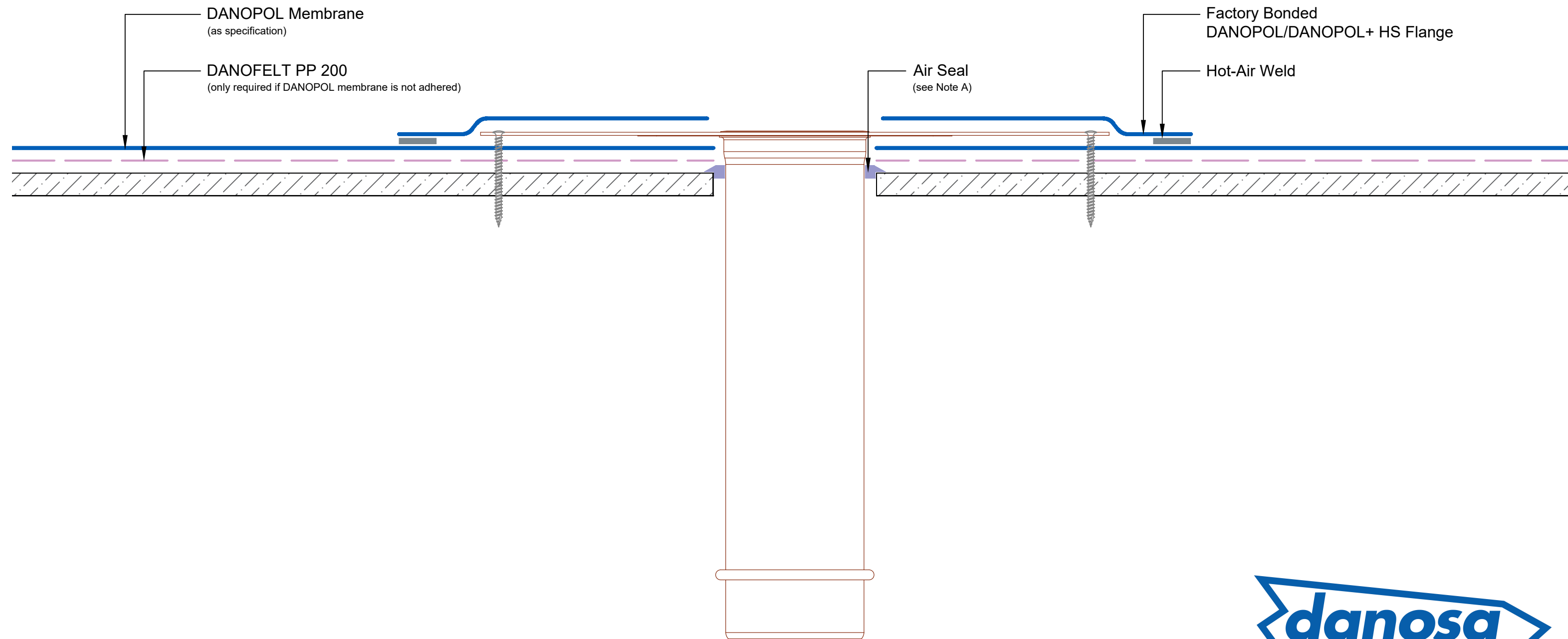

Drawing Number: DUK-S-(G)-300C	Revision: 00
Date Drawn: March 2017	Author: SL

Drawing Title:
Rainwater Outlet
DANOPOL® Single Ply Membranes - Warm Roof



Building together

DANOSA UK Limited

Tel: 0845 074 0553 | www.danosa.co.uk | uktechnical@danosa.com