



**INSTITUTO DE CIENCIAS  
DE LA CONSTRUCCIÓN  
EDUARDO TORROJA**

*C/ Serrano Galvache n. 4. 28033 Madrid (Spain)  
Tel.: (34) 91 302 04 40 / Fax: (34) 91 302 07 00  
[direccion.ietcc@csic.es](mailto:direccion.ietcc@csic.es) [www.ietcc.csic.es](http://www.ietcc.csic.es)*



## European Technical Assessment

**ETA 10/ 0054  
of 09/01/2016**

English translation prepared by IETcc. Original version in Spanish language

### General Part

**Technical Assessment Body issuing the ETA and designated according to Article 29 of the Regulation (EU) Nº305/2011:**

Instituto de Ciencias de la Construcción Eduardo Torroja (IETcc)

**Trade name of the construction product**

**DANOPOL HS FM**

**Product family to which the construction product belongs**

Systems of mechanically fastened flexible PVC roof waterproofing membranes.

**Manufacturer**

DERIVADOS ASFALTICOS NORMALIZADOS (DANOSA), S.A  
Sector 9, Polígono Industrial. 19290 – FONTANAR GUADALAJARA. España. Spain

**Manufacturing plant(s)**

Sector 9, Polígono Industrial. 19290 – FONTANAR GUADALAJARA. Spain

**This European Technical Assessment contains**

14 pages including 1, Annex which form an integral part of this assessment.  
Annex 2. Contain confidential information and is not included in the ETA when that assessment is publicly available

**This European Technical Assessment is issued in accordance with regulation (EU) No 305/2011, on the basis of**

Guideline for European Technical Approval (ETAG) nº 006, used as European Assessment Document (EAD)

**This version replaces**

ETA 10/0054 issued on 30/ 11/ 2012

Translations of this European Technical Assessment in other languages shall fully correspond to the original issued document and should be identified as such.

Communication of this European Technical Assessment, including transmission by electronic means, shall be in full (excepted the confidential Annex(es) referred to above). However, partial reproduction may be made, with the written consent of the issuing Technical Assessment Body. Any partial reproduction has to be identified as such.

This European Technical Assessment may be withdrawn by the issuing Technical Assessment Body, in particular pursuant to information by the Commission according to Article 25 Paragraph 3 of Regulation (EU) No 305/2011.

## SPECIFIC PARTS OF THE EUROPEAN TECHNICAL ASSESSMENT

### 1 Technical description of the product

DANOPOL HS is single reinforced flexible practised Polyvinyl Chloride (PVC) waterproofing roof Kit fastened mechanically, with a slope exceeding 1%. The membrane is fastened with metallic point fasteners in area of overlapping at edge of membrane, before it is welded with the following membrane. The Kit is composed by flexible membranes of PVC, manufactured by the holder of the approval and mechanical fasteners manufactured by others manufacturers

**Main membranes:** DANOPOL HS 1.2, DANOPOL HS 1.5, DANOPOL HS 1.8 and DANOPOL HS 2.0. DANOPOL FR HS 1.2, DANOPOL FR HS 1.5, DANOPOL FR HS 1.8 and DANOPOL FR HS 2.0. DANOPOL HSF 1.2 and DANOPOL HSF 1.5

#### Mechanical fasteners.

Type	Fasteners	Washer	Axial load (N) on Profiled metal
Metallic	EJOT Dabo SW 8 RT-4,8	EJOT HTV 82/40	1060
Plastic	GUARDIAN BS 4.8	GUARDIANR 45 Ø	1170
	ISODRILL TT IS	ETANCOPLAST HP4L 40	1330
Induction	GUARDIAN BS-6,1	GUARDIAN WELD 80 Ø (PVC)	1680
	OMG XHD	OMG Rhinobond 80 Ø (PVC)	1420

Other fasteners with CE mark according to European technical approvals based on ETAG 006 can be used in this system. These fasteners are included in annex 1 for different kinds of supports, which comply with the requirements of this ETA.

The kit supplier is also responsible that only fasteners are used which fulfil the requirements of the AoC procedure. The assessment of this Kit does not include the thermal insulation. The thermal isolation often used with this kit are panels of: mineral wools, Polyisocyanurate, polyurethane and cellulose. The supports often used with this kit are: Corrugated steel plates, corrugated steel of punched or bursted surface, Concrete, Aerated concrete, Wood and wooden boards.

### 2 Specification of the intended use in accordance with the applicable EAD

The intended use of this product is the waterproofing of roofs with slopes exceeding 1%, preventing the passage of water pass into the interior of the building, both in liquid or vapour form. This assembled system complies with Essential Requirements 2, 3 and 4: Safety in the case of fire, Hygiene, health and environment, and Safety in use, of Regulation EU N°305/2011.

The provisions made in this ETA are based on an assumed intended working life of the assembled system at least of 10 years. The indication given on the assumed intended working life cannot be interpreted as a guarantee given by the manufacturer, but are only to be regarded as a means for choosing the right products in relation to the expected economically reasonable working life of the works.

"Assumed intended working life" means that, when an assessment following the ETAG provisions is made, and when this working life has elapsed, the real working life may be, in normal use conditions, considerably longer without major degradation affecting the Essential Requirements.

**Installation.** The fitness for use of this DANOPOL HS FM system can only be assumed if installation is carried out according to the manufacturer's instructions. It is the responsibility of the manufacturer to guarantee that the information on the application of its products is correctly given to the users. Particularly, it is recommended to consider:

Overlap. The longitudinal overlap between membranes must be  $\geq 10$  cm and transversal one  $\geq 5$  cm. The welding can be performed by hot air or a chemical agent THF.

Fasteners. Mechanical fastening of the Systems is carried out on the overlaps, using the mentioned fasteners, and where the washers must be applied at a distance from the edge of the membrane  $\geq 1$  cm.

Minimum distance between fasteners must be 12 cm, and maximum 1m. Maximum distance between rows of fasteners is the width of the membrane less the distance of the fastener to the edge of the membrane. The number of fasteners per square metre is determined by the varying air pressure on the roof, which depends on the geographic area, area of the roof and height of the building. For the number of fasteners/m<sup>2</sup> the wind uplift resistance of the fastener and the national regulations and administrative provisions of the member state of destination shall be taken into account.

**Intersection at protruding elements.** At the intersections with protruding elements (duct for utility installations, etc.) the waterproofing is finished off on a smooth metal profile. This support/profile is anchored mechanically to the fretwork sheet, installed to remain independent of the duct element, which is mechanically fastened to the support deck.

**Structural joint.** Prior to installation of the membrane and insulation, the structural joint formation profiles must be made available according to the drawing (Fig 1), i.e. plate anchored on one side (flat metal sheet) over the fretwork sheet as carrier of the joint insulation, anchoring of the joint formation base profiles (the separation of which will depend on foreseen movement) and insulation of the joint centre, which must be installed prior to closing the second profile.

**Intersection at vertical facing.** Intersection at vertical facings is carried out by following the drawing in Fig.2.

**Gutter catch basins.** It must be used gutter made by PVC-P with rigid wing with a minimum width of 6 cm. The waterproofing shall be performed according to Fig. 3.

**Roof light.** The waterproofing shall be performed according to Fig. 4.

**Traffic areas.** The traffic areas will be correctly protected (light tiles, etc..) to avoid damages in the waterproof membrane.

**Use, maintenance and repair of the works.** Assessment of the fitness for use is based on the assumption that periodical maintenance of the roof is carried out. Maintenance must include:

- Inspection of the roof at regular intervals.
- Cleaning of downpipes and filters.
- Removal of stones, branches and leaves, etc.
- Inspection of flashing along the edges of the roof, chimneys, drains, skylights, etc.

If the Waterproofing System has been damaged, and is causing leakage, qualified installers must repair it immediately. Maintenance, preservation or remedial work personnel must wear footwear with a suitable sole. Further details are laid down in the MTD located at IETcc.

### 3 Performance of the product and references to the methods used for its assessment

Assessment of the fitness of the DANOPOL HS Kit for the intended use, with regard to Essential Requirements 2, 3 and 4, was performed in compliance with the "Guideline of Systems of mechanically fastened flexible roof waterproofing membranes" (ETAG 006).

The characteristics of this Kit show values, which are within the requirements and tolerances established in the Manufacturer's Technical Dossier (MTD)<sup>1</sup>, and which are shown below. This assessment could be extended with other requirements applicable to dangerous substances resulting from transposed European legislation or national regulations and administrative provisions. Moreover, this assessment could be extended with other requirements applicable to the products, resulting from the application of other national regulations and administrative provisions.

#### 3.1 Characteristics of the Kit

##### Safety in the case of fire (BWR 2)

**External fire performance.** Classification according to EN 13501.

Membrane	External fire performance classification	Support	Slope
DANOPOL HS	Broof(t1)	MW* / EPS*	<10°
	Broof(t3)	MW / EPS	<10°
	Broof(t4)	MW / PIR	All slopes
DANOPOL FR HS	Broof(t2)	MW	All slopes

\*The insulation materials used in the test were EPS 100 S thickness 120mm, mineral wood with a fire reaction A1, thickness of 100mm, density of 130-150 kg/m<sup>3</sup> and PIR 100 mm and density of 32 kg/m<sup>3</sup>.

<sup>1</sup> "The manufacturer's technical dossier (MTD) comprises all information necessary for the production and the processing of the product as well as for the repair of the waterproofing made from that. IETcc checked it and it was found to be in accordance with the conditions stated in the approval and the characteristic value determined during the approval testing. The part of the MTD to this ETA to be treated confidentially (inter alia the control plan for factory production control and initial type-testing is deposited with IETcc and, as far as this is relevant to the tasks of the notified body involved in the procedure of attestation of conformity shall be handed over to the notified body."

Hygiene, health and environment (BWR 3)

**Release of dangerous substances.** According to the manufacture's statement, the product does not contain any dangerous substance according to the EU database.

Safety in use (BWR 4)

**Wind uplift resistance.** The Kit tested is the constituted by the main membrane DANOPOL HS 1.2. The results were:

Fasteners	Washer	W test	W adm
EJOT Dabo SW 8 RT-4,8 Metallic	EJOT HTV 82/40 (metallic)	1000	600
ISODRILL TT IS	ETANCOPLAST HP4L 40 Ø (plastic)	893	493
GUARDIAN BS 4.8	GUARDIANR 45 Ø (plastic)	1000	600
OMG XHD	RHINOBOND PLATE (Induction)	1200	733
GUARDIAN BS-6,1	GUARDIAN WELD 80 Ø (Induction))	1500	900

**3.2 Membrane Performance**Safety in case of fire (BWR 2)

**Reaction to fire.** Euroclase E (EN 13925-2), according to EN 13501

Hygiene, health and environment (BWR 3)

Performance	Units	Standard	Hot air	THF
Resistance Peel resistance of joints	Maximum (N/50 mm) (L/T)	EN 12316-1	206 / 270	204 / 253
	Average (N/50 mm) (L/T)		185 / 220	170 / 215
R. Shear resistance of joints	N/50 mm (L/T)	EN 12317-1	1143 / 1162	1106 / 1142
R. Tear resistance (nail) (1,2)	N (L/T)	EN 12310-1	230 / 245	
Low temperature bending/folding	T°C	EN 1109	-30	
Watertightness		EN 1928	Watertight	
Water vapour permeability	μ	EN 1931	47.000	
Tensile properties (1,2)	Tensile strength (N/5cm) (L/T)	EN 12311-1	1064 / 1002	
	Elongation (%) (L/T)		131 / 53	
Static loading resistance	kg	EN 12730	30	
Dynamic loading resistance	(φ)mm	EN 12691	700	

Safety in use (BWR 4)

**Slipperiness.** NPA

Aspects related to durability and serviceability

**Heat exposure resistance** (EN 1296). The samples are exposed to a temperature of  $70 \pm 2^\circ\text{C}$  during 168 days, after which the following tests are carried out:

Performance	Units	Results
Peel resistance	L/T (N/50mm)	162 / 142 (Max/ med) // 216/195 (Max/med)
Shear resistance	L/T(N/50mm)	1133 / 1146
Low temperature bending/folding	Upper face // Down face (°C)	- 30

The results obtained show acceptable behaviour of the membranes, as the decrease in peel and shear resistance is less than 20% and the decrease in the resistance to cold bending/folding is below  $-15^\circ\text{C}$ .

**Resistance to UV-radiation in the presence of moisture.** The specimens were exposed to UV radiation during 2000 hours and the low temperature flexibility was determined. The membranes don't crack at  $-25^\circ\text{C}$ .

**Dimensional stability** (EN 1107). Longitudinal 0,2% and transversal 0,02 %. Results obtained show acceptable behaviour of the membrane, since their dimensional stability for non-reinforced was less than 0.6 % for reinforced membranes.

**3.3 Performances of mechanical fasteners**Safety in use (BWR 4)

**Axial load.** The axial load obtained on the screw supplied by the manufacturer (see point 1)

**Resistance to unwinding.** Pass

**Resistance to peel.**Aspects related to durability and serviceability

**Resistance to corrosion.** The screws and washers used offer a corrosion resistance of 15 Kesternich cycles.

**Peel resistance of the membrane- washer (EN 12316-2).** The membrane of 1.2 mm is fixed to the washer by induction procedure. The test is performed at 100 mm/min. The test is described in the picture.

Welding	OMG PVC Treadsafe plate 80 Ø (N)			GUARDIAN WELD 80 Ø (N)		
	Initial	84d at 70°C	28d in water	Initial	84d at 70°C	28d in water
Values	1570	1253	1561	1268	1258	1352

The failure of the test is due to the rupture of the membrane.

**3.4 Identification of components**

**Main membrane (DANOPOL HS, DANOPOL FR HS, DANOPOL HSF).** Membranes manufactured from PVC plastificated reinforced by an internal polyester fibre mesh with CE mark according to ZA annex to the EN 13956. The main characteristics of this membrane are:

Characteristics	DANOPOL HS 1.2	DANOPOL HS 1.5	DANOPOL HS 1,8	DANOPOL HS 2.0
Thickness (mm)	1.2 (-5%; +10%)	1.5 (-5%; +10%)	1.8 (-5%; +10%)	2.0 (-5%; +10%)
Width (m)	1.06 / 1.80 (-0,5%, +1%)			
Weight (kg/m <sup>2</sup> )	1.5 (-5%, +10%)	1.9 (-5%, +10%)	2.3 (-5%, +10%)	2.6 (-5%, +10%)
Roll dimensions (m)	25 / 20 (-0%, +5%)	20 / 15 (-0%, +5%)	17 / 13 (-0%, +5%)	15 / 11 (-0%, +5%)
Roll weight (kg)	41.6/56.2	41.7/52.9	42.3/54.7	42.3/52.4
Colour	Ligth Grey/ Dark Grey/ Cool Roofing (White)			

**Fasteners.** The characteristics of the fasteners are including in Annex 1.

**4. Assessment and verification of constancy of performance (AVCP) system applied, with reference to its legal base**

**System of Attestation of Conformity.** The European Commission according to the decision (98/143/EC of February 1998, Official Journal of the European Communities No. L 42, 14.02.1998) on the Procedures of Attestation of Conformity (Annex III, clause 2(ii) first possibility of EU Regulation 305/2011) for Systems of mechanically fastened flexible roof waterproofing membranes.

Product	Intended uses	Level or Classes	System
DANOPOL HS	Systems of mechanically fastened flexible PVC roof waterproofing membranes	Any	+2

According to this decision, system +2 establishes: *Tasks of the manufacturer:* Factory production control and Initial type-testing of the product and *Tasks of the notified body:* Initial inspection of the factory and production control and Continuous surveillance, assessment and approval of factory production control.

**5 Technical details necessary for the implementation of the AVCP system, as provided for the applicable EAD**

The ETA is issued for this kit on the basis of agreed data/information, deposited at IETcc, which identifies the product that has been assessed and judged. It is the manufacturer's responsibility to make sure that all those who use the kit are appropriately informed of specific conditions according to sections 1, 2, 4 and 5 including the annexes of this ETA. Changes to the membrane or the components or their production process, which could result in this deposited data/information being incorrect should be notified to the IETcc before the changes are introduced. IETcc will decide whether or not such changes affect the ETA and if so whether further assessment or alterations to the ETA shall be necessary.

**5.1 Tasks of the manufacturer**

**Factory production control.** The manufacturer shall exercise permanent internal control of production and ensure that the results obtained comply with the quality level required. All the elements, requirements and provisions adopted by the manufacturer are documented in a systematic manner in the form of written procedures and regulations. This control production system documentation ensures a common understanding of quality assurance and enables the achievement of the required product characteristics according to the ETA.

The manufacturer may only use components stated in the technical documentation of this ETA including Control Plan. The incoming raw materials are subjected to verifications by the manufacturer before acceptance.

The factory production control shall be in accordance with the Control Plan<sup>(2)</sup> which is part of the Technical Documentation of this ETA. The Control Plan has been agreed between the manufacturer and the IETcc and is laid down in the context of the factory production control system operated by the manufacturer and deposited at the IETcc. The results of factory production control shall be recorded and evaluated in accordance with the provisions of the Control Plan.

**Initial type-testing of the product.** Initial type-testing carried out by the IETcc is that set out in chapter 5 of the guideline for Systems of mechanically fastened flexible roof waterproofing membranes (ETAG 006). The IETcc assessed the results of these tests in accordance with chapter 6 of this Guide, as part of the ETA issuing procedure.

If the verifications underlying this ETA have been furnished on samples from the current production, these will replace the initial type-testing. Otherwise the necessary initial type-testing shall be carried out according to the provisions of the test plan and observance of the required property values shall be ascertained by the notified body. After changing the production process or starting the production in another manufacturing plant the initial type-test shall be repeated.

**Other tasks of the manufacturer.** The manufacturer shall, on the basis of a contract, involve a body which is notified for the tasks referred to in section 4 in the field of LARWK in order to undertake the actions laid down in this clause. For this purpose, the control plan shall be handed over by the manufacturer to the notified bodies involved.

For initial type – testing, the results of the tests performed as part of the assessment for the ETA shall be used unless there are changes in the production line or plant. In such cases the necessary initial type- testing has to be agreed with the IETcc.

The manufacturer shall make a declaration of conformity, stating that the construction product is in conformity with the provisions of this ETA

## 5.2 Tasks of the Notified body

**Initial inspection of factory and production control.** The notified body ascertains that, in accordance with the MTD, factory conditions and production control allow the manufacturer to ensure the consistency and homogeneity of the manufactured product and its traceability, thus guaranteeing that the final characteristics of the product are those indicated in point 2.

**Continuous surveillance, assessment and approval of Factory Production Control.** The Notified body shall visit the factory at least twice a year. Surveillance of the manufacturing process shall include:

- Checking the documentation of factory production control, to ensure continuing compliance with the provisions of the ETA,
- Identification of changes by comparing data obtained during the initial inspection or during the last inspection.

In the event the ETA provisions are not complied with, the certificate of conformity shall be withdrawn.

---

<sup>(2)</sup> The control plan is a confidential part of this European Technical Assessment and only handed over to the notified body involved in the procedure of attestation of conformity.

Issued in Madrid on 09 January 2017.  
by



Instituto de Ciencias de la Construcción Eduardo Torroja  
**CONSEJO SUPERIOR DE INVESTIGACIONES CIENTÍFICAS**  
c/ Serrano Galvache 4. 28033 Madrid (Spain).  
[director.ietcc@csic.es](mailto:director.ietcc@csic.es) [www.ietcc.csic.es](http://www.ietcc.csic.es)



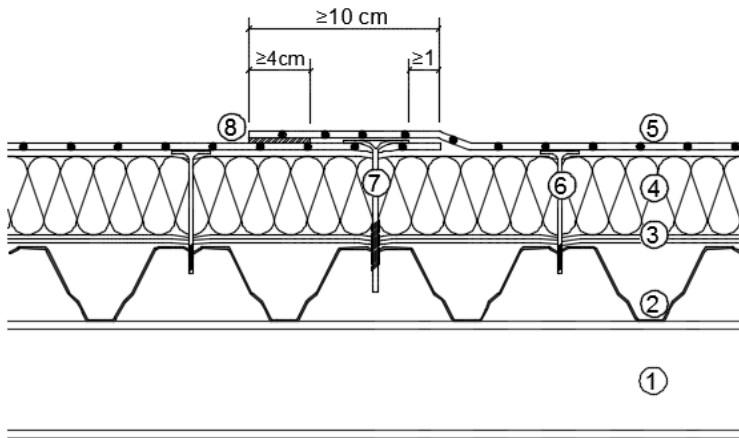
On behalf of the Instituto de Ciencias de la Construcción Eduardo Torroja

A handwritten signature in blue ink, appearing to read 'Marta Castellote', with a long horizontal line extending to the right.

Marta M<sup>o</sup> Castellote  
Director

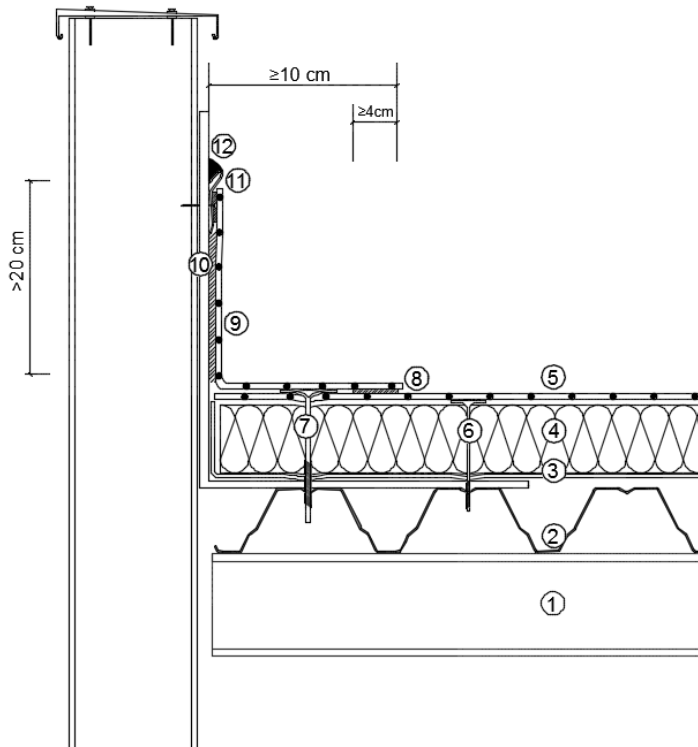


**Fig. 1 Membrane Overlap Detail**



- ① Main structure
- ② Resistant steel basis
- ③ Vapour barrier DANOPOL 250 BV
- ④ Thermal insulation
- ⑤ Main waterproofing membrane DANOPOL HS
- ⑥ Insulation mechanical fixing
- ⑦ Waterproofing mechanical fixing
- ⑧ Thermoplastic welding

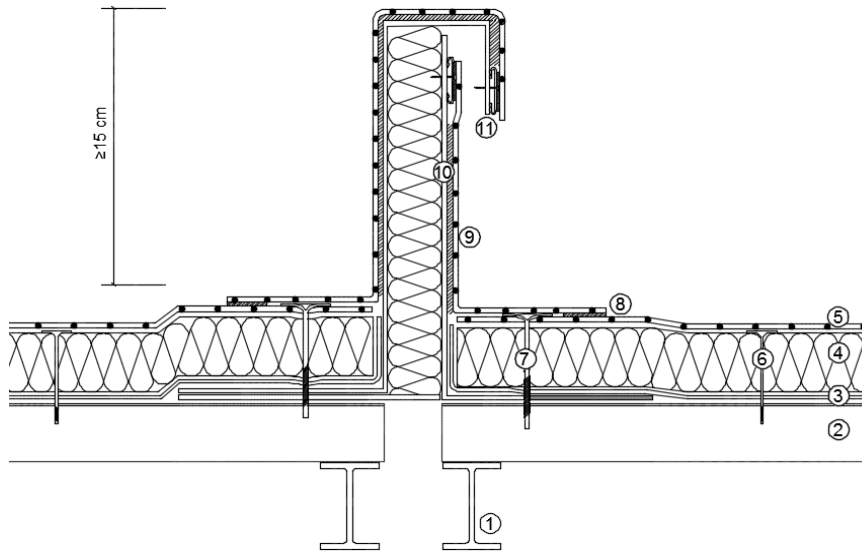
**Fig. 2 Parapet Detail**



- ① Main structure
- ② Resistant steel basis
- ③ Vapour barrier DANOPOL 250 BV
- ④ Thermal insulation
- ⑤ Main waterproofing membrane DANOPOL HS
- ⑥ Insulation mechanical fixing
- ⑦ Waterproofing mechanical fixing
- ⑧ Thermoplastic welding
- ⑨ Perimeter waterproofing membrane DANOPOL HS
- ⑩ Adhesive GLUE DAN PVC
- ⑪ Laminated profile DANOSA
- ⑫ Elastic sealant ELASTYDAN PU 40 grey

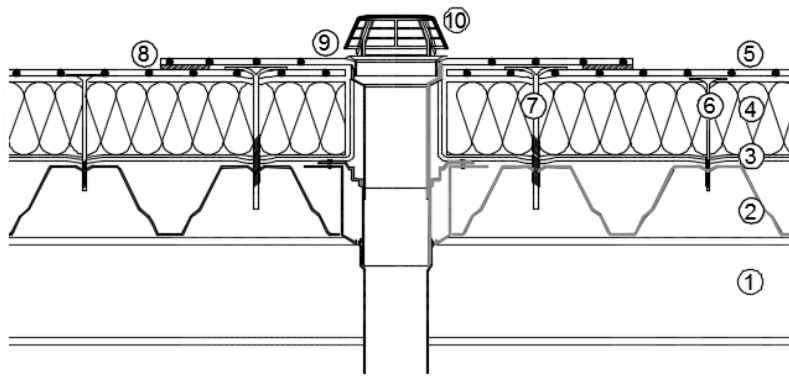
**Structural Joint Detail**

**Fig. 3**



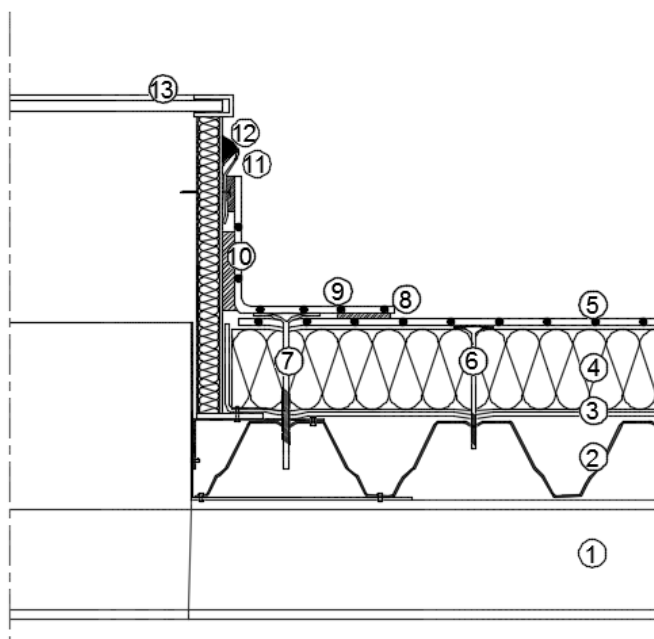
- ① Main structure
- ② Resistant steel basis
- ③ Vapour barrier DANOPOL 250 BV
- ④ Thermal insulation
- ⑤ Main waterproofing membrane DANOPOL HS
- ⑥ Insulation mechanical fixing
- ⑦ Waterproofing mechanical fixing
- ⑧ Thermoplastic welding
- ⑨ Perimeter waterproofing membrane DANOPOL HS
- ⑩ Adhesive GLUE DAN PVC
- ⑪ Laminated profile DANOSA

**Fig. 4 Vertical Drain Detail**



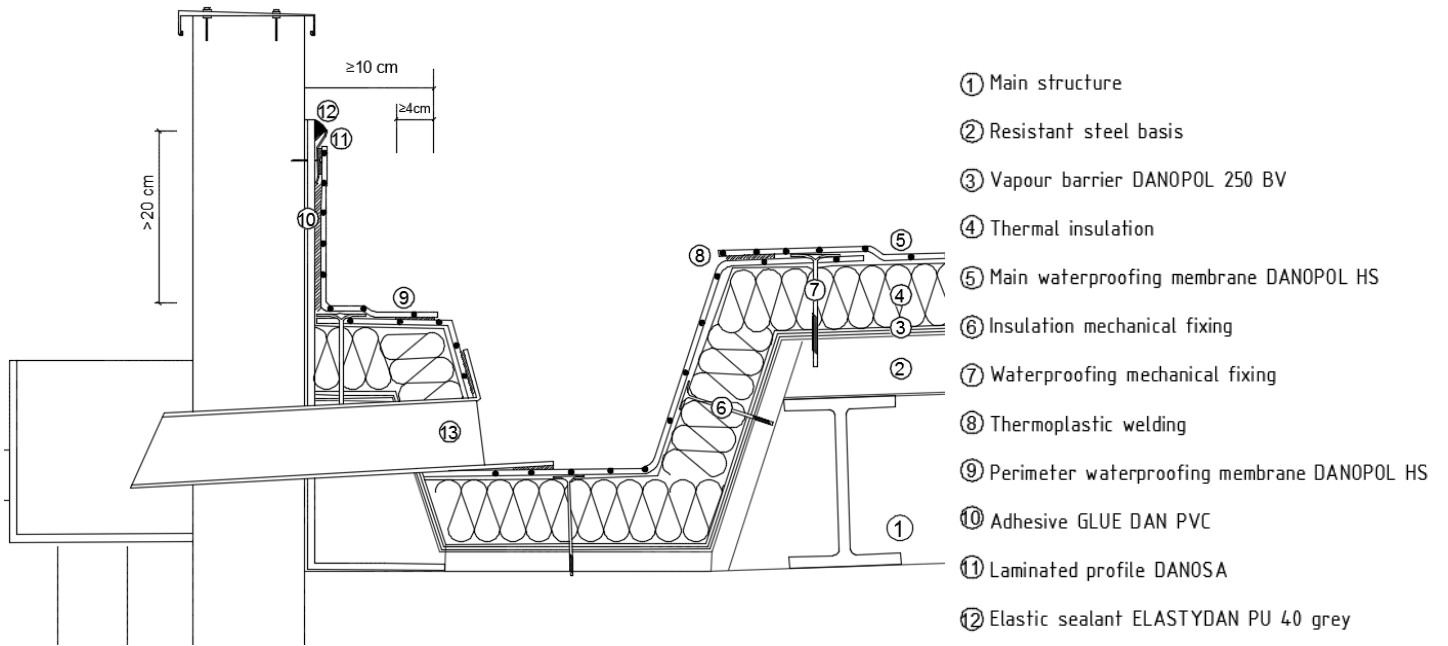
- ① Main structure
- ② Resistant steel basis
- ③ Vapour barrier DANOPOL 250 BV
- ④ Thermal insulation
- ⑤ Main waterproofing membrane DANOPOL HS
- ⑥ Insulation mechanical fixing
- ⑦ Waterproofing mechanical fixing
- ⑧ Thermoplastic welding
- ⑨ Vertical PVC drain DANOSA
- ⑩ Gravel stop DANOSA

**Fig. 5 Skylight Detail**

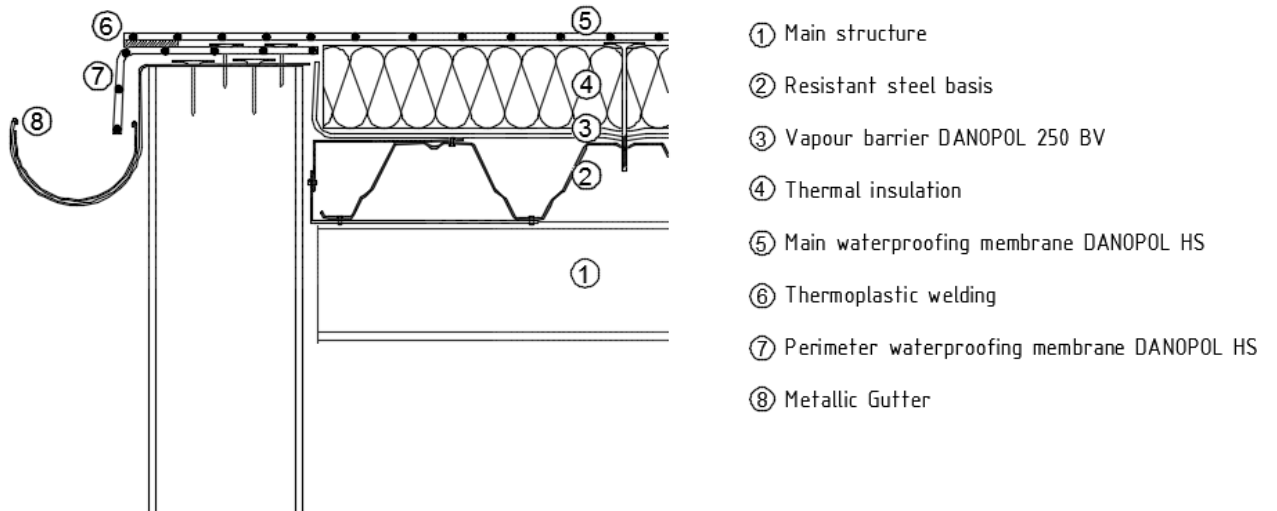


- ① Main structure
- ② Resistant steel basis
- ③ Vapour barrier DANOPOL 250 BV
- ④ Thermal insulation
- ⑤ Main waterproofing membrane DANOPOL HS
- ⑥ Insulation mechanical fixing
- ⑦ Waterproofing mechanical fixing
- ⑧ Thermoplastic welding
- ⑨ Perimeter waterproofing membrane DANOPOL HS
- ⑩ Adhesive GLUE DAN PVC
- ⑪ Laminated profile DANOSA
- ⑫ Elastic sealant ELASTYDAN PU 40 grey
- ⑬ Insulated skylight DANOSA EVACUM

**Fig. 6 Punctual lateral Gutter Detail**



**Fig. 7 Lateral Gutter Detail**



## Annex 1

This annex includes a different kind of fasteners, which comply with the requirement of this ETA.

Profiled metal deck substrate	Axial Load (N)	W adm (N / fastener)	N° ETA
EDS BZT/BGT + DVP-EF/DF 8240 D (EUROFAST)	1230	600	06/0007
EDS BZTR/BGTR + DVP-EF DF 8040D (EUROFAST)	1090	600	06/0007
EDS BZT/BGT + DVP-EFZK 8240 D (EUROFAST)	1340	600	06/0007
EDS BZTR/BGTR + DVP-EFZK 8240 D (EUROFAST)	1090	600	06/0007
EDS BZT/BGT + DVP-EF 8040 D/N/H/XH (EUROFAST)	1320	600	06/0007
EDS BZTR/BGTR+. DVP-EF 8040 D/N/H/XH (EUROFAST)	1090	600	06/0007
EDS BZT/BGT + Eurofast DVP-EF 5010 N/D (EUROFAST)	1340	600	06/0007
EDS BZTR/BGTR + DVP-EF 5010 N/D (EUROFAST)	1090	600	06/0007
EDS B + TLK-45 (plastic) (EUROFAST)	1080	553	06/0007
EDS S + TLK-45 (plastic) (EUROFAST)	1340	600	06/0007
EDS B + TRP-45 (plastic) (EUROFAST)	1260	600	06/0007
EDS S + TRP-45 (plastic) (EUROFAST)	1260	600	06/0007
<b>SW 8 RT 4,8xL + HTV 82 x 40 (EJOT) (reference)</b>	<b>1060</b>	<b>600</b>	<b>07/0013</b>
TKR 4.8xL + HTK 2G (plastic) (EJOT)	1060	454	07/0013
VHT-R 4.8xL + HTK 2G (plastic) (EJOT)	940	437	07/0013
<b>ISODRILL TT IS (plastic)+ Etancoplast HP4 L Ø40 (LR ETANCO) reference</b>	<b>1330</b>	<b>493</b>	<b>08/0239</b>
EVDF 2C 4,8 XL + 82x40 R DF (LR ETANCO)	1740	600	08/0239
EVDF 2C 4,8 X L + 82x40 R SC (LR ETANCO)	1740	600	08/0239
EVDF 2C 4,8 XL + 82x40 R DF (LR ETANCO)	1400	600	08/0239
EVDF 2C 4,8 XL + 82x40 R SC (LR ETANCO)	1420	600	08/0239
EHDF2C 4,8 XL + 82x40 R DF (LR ETANCO)	1350	600	08/0239
EHDF2C 4,8 XL + 82x40 R SC (LR ETANCO)	1350	600	08/0239
ISODRILL TH DF + 82 x 40 R DF (LR ETANCO)	1320	600	08/0239
ISODRILL TT+ T 80 x 40 (LR ETANCO)	1320	600	08/0239
ISODRILL TT+ Etancoplast HP 82x 40 (LR ETANCO)	1320	600	08/0239
EGB 2C + Etancoplast HP 82 x 40 (LR ETANCO)	1450	600	08/0239
EGB 2C + Etancoplast T80 x 40 (LR ETANCO)	1430	600	08/0239
ZDBS + ZLVT001 (ZAHN)	970	540	08/0033
PS 4.8 + SP(A)-8240 (steel 0,70mm)(GUARDIAN)	1310	600	08/0285
BS 4.8 + SP(A)-8240 (steel 0,70mm)(GUARDIAN)	1170	600	08/0285
BS 4.8 + TB(P) 8040 (steel 0,75mm)(GUARDIAN)	1450	540	08/0285
BS 6.1 + SP(A)-8240 (steel 0,70mm)(GUARDIAN)	1780	600	08/0285
DBT(A) 4.8 + SP(A)-8240 (steel 0,70mm)(GUARDIAN)	1170	600	08/0285
PS 4.8 + R45 (steel 0,70mm) (plastic)(GUARDIAN)	1310	600	08/0285
<b>BS 4.8 + R45 (steel 0,70mm) (plastic)(GUARDIAN R45 Ø ) (reference)</b>	<b>1170</b>	<b>600</b>	<b>08/0285</b>
BS 6.1 + R45 (steel 0,70mm) (plastic)(GUARDIAN)	1780	600	08/0285
IR2-4,8 + IR 82x40 (SFS INTEC)	1030	600	08/0262
BS-4,8 + RP45 (plastic)(SFS INTEC)	1080	553	08/0262
<b>Induction systems</b>			
GUARDIAN BS6,1+GUARDIAN WELD 80 PVC (steel 0,75mm)	1680	900	08/0285
GUARDIAN BS6,1+GUARDIAN WELD 80 PVC (steel 1,00mm)	1690	900	08/0285
OMG XHD + RHINOBOND PVC PLATE 80Ø (steel 0,70mm)	1420	733	09/0337
<b>Profiled metal deck substrate (acoustic)</b>	<b>Axial Load (N)</b>	<b>W adm (N / fastener)</b>	<b>N° ETA</b>
IFP2 + IRP 82x40 (SFS INTEC)	870	492	08/0262
<b>Lightweight concrete substrate</b>	<b>Axial Load (N)</b>	<b>W adm (N / fastener)</b>	<b>N° ETA</b>
GBS/GBS A2 + DVP-EFB 8040D (EUROFAST)	1340	600	06/0007
GBS/GBS A2 + DVP-EF 8040 D/N/H/XH (EUROFAST)	1440	600	06/0007
FPS-E-8 x L + HTV 82 x 40 F (EJOT)	1720	600	07/0013
FDDPlus-50 (plastic) (EJOT)	1340	600	07/0013
MULTIFAST TB INOX A2 + 82x40 R (LR ETANCO)	1540	600	08/0239
LBS 6.0 + SP-8240 (600kg/m3) (GUARDIAN)	2070	600	08/0285
LBS 6.0 + TB(P) 8040 (600kg/m3) (GUARDIAN)	2070	540	08/0285
LBS 8.0 + SP-8240 (450kg/m3) (GUARDIAN)	930	600	08/0285
LBS 8.0 + SP-8240 (550kg/m3) (GUARDIAN)	1440	600	08/0285
LBS 6.0 + R45 (600Kg/m3) (plastic) (GUARDIAN)	2070	600	08/0285
LBS 8.0 + R45 (550Kg/m3) (plastic) (GUARDIAN)	1440	600	08/0285
IGR-S 8,0xL + IG8-C 82 X 40 (SFS INTEC)	930/1440	600	08/0262

Concrete	Axial Load (N)	W adm (N / fastener)	Nº ETA
EFHD + DVP-EF 8240 D (EUROFAST)	3510	600	06/0007
EFHD + DVP-EF 8040 D/N/H/XH (EUROFAST)	3510	600	06/0007
DFCF + DVP-EF 8040 D/N/H/XH(EUROFAST)	3510	600	06/0007
EFHD + TLK-45 (plastic) (EUROFAST)	1510	600	06/0007
VRF ISPC 50 (plug-in).	1650	600	06/0007
EFR + TRP-45 (plastic) (EUROFAST)	1260	600	06/0007
FBS-R-6,3 + HTV 82 x 40 F(EJOT)	1780	600	07/0013
FDDPlus-50 (plastic) (EJOT)	1350	540	07/0013
ZBST + ZLVT0012(82X40) (ZAHN)	1600	600	08/0033
BETOFAST TT 2C + Etancoplast T 80 X 40(LR ETANCO)	2970	600	08/0239
BETOFAST TT 2C + Etancoplast HP 82 X 40(LR ETANCO)	2990	600	08/0239
CS/ACS 6.1 + SP-8240 (C25-30)(GUARDIAN)	4280	600	08/0285
CS/ACS 6.1 + TB(P) 8040 (C25-30)(GUARDIAN)	2520	600	08/0285
BN 5.6 + SP-8240 (C25-30) (GUARDIAN)	1390	600	08/0285
BNRF 5.5 + SP-8240 (C25-30) (GUARDIAN)	1790	600	08/0285
CS/ACS 6.1 + R45 (C25-30) (plastic)(GUARDIAN)	4280	600	08/0285
CP (C25-30) (plastic)(GUARDIAN)	1570	600	08/0285
TI 6,3 + IF/IG-C 82 X 40(SFS INTEC)	1830	600	08/0262
TI 6,3 + IRD 82 X 40(SFS INTEC)	1830	600	08/0262
TI-T25 6,3 + R45 (plastic)(SFS INTEC)	1420	600	08/0262
DT-S-4,8+ R45 (plastic)(SFS INTEC)	1390	600	08/0262
Wood substrate	Axial Load (N)	W adm (N / fastener)	Nº ETA
EDS-H + DVP-EFB 8040D (EUROFAST)	1340	600	06/0007
EDS-H + DVP-EF 8040 D/N/H/XH (EUROFAST)	1050	600	06/0007
EDS-H + TLK-45 (plastic) (EUROFAST)	990	507	06/0007
EDS-H + TRP-45 (plastic) (EUROFAST)	1160	594	06/0007
SW 8 R 4,8 x L + HTV 82 x 40 (EJOT)	1080	600	07/0013
TKR 4.8xL + HTK 2G (EJOT)	1080	600	07/0013
VHT-R 4.8xL + HTK 2G (EJOT)	1300	600	07/0013
ZHBK + ZLVT 001 (82x40) (ZAHN)	1201	600	08/0033
EVDF 2C + 82x 40 R SC(LR ETANCO)	1830	600	08/0239
EVDF 2C + 82x 40 R DF(LR ETANCO)	1880	600	08/0239
MULTIFAST TF + 82 x 40 R (LR ETANCO)	1990	600	08/0239
TS 5.2 + SP-50/F/S/D (18mm softwood G4-2)(GUARDIAN)	1280	600	08/0285
TS 5.2 + SP-50/F/S/D (23mm softwood G4-2) (GUARDIAN)	1900	600	08/0285
TS 5.2 + SP-50/F/S/D (18mm OSB/3) (GUARDIAN)	1350	600	08/0285
TS 5.2 + SP-50/F/S/D (18mm chipboard) (GUARDIAN)	1180	600	08/0285
TS 5.2 + SP-50/F/S/D (18mm multilayer wood deck) (GUARDIAN)	1890	600	08/0285
TS 5.2 + SP-8240 (18mm wood deck underlayment) (GUARDIAN)	1940	600	08/0285
TS 5.2 + TB(P) 8040 (18mm wood deck underlayment)(GUARDIAN)	1940	600	08/0285
LBS 6.0 + SP-8240 (18mm OSB/3) (GUARDIAN)	1400	600	08/0285
LBS 6.0 + SP-8240 (23mm softwood G4-2) (GUARDIAN)	2000	600	08/0285
LBS 6.0 + R45 (18mm OSB/3) (plastic)(GUARDIAN)	1400	600	08/0285
LBS 6.0 + R45 (23mm softwood G4-2) plastic)(GUARDIAN)	2000	600	08/0285
IG 6,0 + IRD 82x40 (19mm particle board)(SFS INTEC)	1970	600	08/0262
IG 6,0 + IRD 82x40 (18mm OSB/3)(SFS INTEC)	1310	600	08/0262
IG 6,0 + IRD 82x40 (22mm structural timber)(SFS INTEC)	1430	600	08/0262

The Wadm has been calculated considering:

- For metallic fasteners: EJOT: SW 8 RT-4,8 + HTV 82/40 with Wadm=600 N
- For plastic fasteners: GUARDIAN: BS 4.8 + R45 Ø with Wadm=600 N  
LR ETANCO: ISODRILL TT IS + ETANCOPLAST HP4L 40 Ø with Wadm= 493 N
- For induction systems: GUARDIAN BS 6,1 + GUARDIAN WELD 80 PVC with Wadm=900N

In order to determine the Wadm of systems with other fasteners (Rnc) and/or substrates according to Annex 1 or separate ETA issued on the basis of ETAG006, the following applies:

Si  $R_{nc} \geq R_{oc}$  :  $W_{adm}(nc) = W_{adm}(oc)$

Si  $R_{nc} \leq R_{oc}$  :  $W_{adm}(nc) = (R_{nc}/R_{oc}) * W_{adm}(oc)$

## Screws description

Screws	Characteristics (with a minimum corrosion resistance of 15 Kesternich cycles).
EVDF 2C (L.R ETANCO)	Steel screw with double-thread under head, Ø4,8mm, length L and a 12mm circular head. Made of hardened carbon steel with a Supracoat corrosion protection.
EVB DF 2C (L.R ETANCO)	Steel screw with double-thread under head, Ø4,8mm, length L and a 12mm circular head. Made of hardened carbon steel with a Supracoat corrosion protection.
EHB DF 2C (L.R. ETANCO)	Steel screw with double-thread under head, Ø4,8mm, length L and a 8 mm hexagonal head. Made of hardened carbon steel with a Supracoat corrosion protection.
ISODRILL TT (L.R ETANCO)	Steel screw, Ø4,8mm, length L and a 8,5mm circular head. Made of stainless steel.
ISODRILL TH DF (L.R ETANCO)	Stainless steel screws with double –thread under head, Ø4,8mm, length L and a 8 mm hexagonal head. Made of stainless steel.
EGB 2C (L.R. ETANCO)	Steel screws, with a diameter of 4,8mm, length L and a 12mm hexagonal head. Made of hardened carbon steel with a Supracoat corrosion protection.
MULTIFAST TF (L.R ETANCO)	Steel screw Ø6mm, length L and a 11mm countersunk head. Made of stainless steel.
FASTOVIS TF 3036 DF 2C (L.R ETANCO)	Steel screw Ø6,5mm, length L and a 11mm countersunk head. Made of hardened carbon steel with a Supracoat corrosion protection.
BETOFAST TT 2C (L.R ETANCO)	Steel screw Ø4,8mm, length L and a 8,5mm circular head. Made of hardened carbon steel with a Supracoat corrosion protection.
MULTIFAST TB INOX A2 (L.R ETANCO)	Steel screw Ø6 mm, length L and a 12mm circular head. Made of stainless steel.
MULTIFAST TF (L.R ETANCO)	Steel screw Ø6mm, length L and a 11mm countersunk head. Made of stainless steel.
IR2 4.8 (SFS intec)	Steel screw double-thread, Ø4,8 mm, length L and a 8mm circular head. Made of hardened carbon steel with a Durocoat corrosion protection.
IFP2 6.7XL (SFS intec)	Steel screw double-thread, Ø6,7 mm, length L and a 11mm flat head. Made of hardened carbon steel with a Durocoat corrosion protection.
TI 6.3 (SFS intec)	Steel screw Ø6,3mm, length L and a 8mm hexagonal head. Made of hardened carbon steel with a Durocoat corrosion protection.
TI-T25 6,3 (SFS intec)	Steel screw Ø6,3mm, length L and a TORX T25 head. Made of hardened carbon steel with a Durocoat corrosion protection.
IGR-S 8 (SFS INTEC)	Steel screw Ø8mm, length L and a 12 mm countersunk head. Made of Austenitic stainless steel
IG 6 (SFS INTEC)	Steel screw Ø6mm, length L and a Ø8mm flat head. Made of hardened carbon steel with a Durocoat corrosion protection.
DT-S-4,8 (SFS INTEC)	Stainless steel dowel Ø4,8mm and a 9,8mm circular head
ZDBS (ZAHN)	Screw with double –thread under head, Ø4,8mm, length L and with a 8 mm hexagonal head. Made of steel treated with an organic coat.
ZGBK (ZAHN)	Steel screw for lightweight concrete support Ø6mm, length L and with a Pozi dricel head. Steel treated with an organic coat.
ZHBK (ZAHN)	Steel screw for wood support w Ø4.8mm, length L and with a Philips Ph2 head. Made of steel treated with an organic coat.
PS 4.8 (GUARDIAN)	Drill point screw for steel deck roofs, Ø4.8mm, length L and TORX T25 head. Made of coated carbon steel treated with Enduroguard 15®
BS 4.8 (GUARDIAN)	S-point screw for steel deck roofs, Ø4.8mm, length L and TORX T25 head. Made of coated carbon steel treated with Enduroguard 15®
BS 6.1 (GUARDIAN)	Drill point screw for steel deck roofs, Ø6.1mm, length L and TORX T25 head. Made of coated carbon steel treated with Enduroguard 30®
DBT(A) 4.8 (GUARDIAN)	Drill point screw for automatic tool for steel deck roofs, Ø4.8mm, length L and a 8mm hexagonal head. Made of coated carbon steel treated with Enduroguard 15®
CS/ACS 6.1 (GUARDIAN)	Concrete screw Ø6.1mm, length L and a TORX T25 head. Made of coated carbon steel treated with Enduroguard 15®
BN 5.6 (GUARDIAN)	Concrete nail Ø5.6mm, length L and a flat head. Made of coated carbon steel treated with Enduroguard 15®
BNRF 5.5 (GUARDIAN)	Concrete nail Ø5.5mm, length L and a flat head. Made of stainless steel
LBS 6.0 (GUARDIAN)	Light weight concrete screw, Ø6.0mm, length L and a TORX T25 head. Made of coated carbon steel treated with Enduroguard 15®
LBS 8.0 (GUARDIAN)	Light weight concrete screw, Ø8.0mm, length L and a TORX T25 head. Made of coated carbon steel treated with Enduroguard 15®
ETANCO OMG #12 STANDARD	Steel screw Ø5.5mm, length L and a PH3 head. Made of zinc steel treated with 30 cycles.
ETANCO OMG #14 HD	Steel screw Ø6,1mm, length L and a PH3 head. Made of zinc steel treated with 30 cycles.
ETANCO OMG #15 XHD	Steel screw Ø6,8mm, length L and a PH3 head. Made of zinc steel treated with 30 cycles.
FPS-E-8,0XI (EJOT)	Self-drilling screw Ø8mm, lengths between 80-240mm and with Torx T30 cylindrical head. Made of stainless steel.
SW8-R-4,8XI (EJOT)	Self-drilling screw Ø4,8mm, lengths between 80-260mm and a 8,0mm hexagonal head. Made of case-hardened steel, treated with Climadur high quality coating.
FBS-R-6,3XI (EJOT)	Self-tapping screw Ø6,3mm, lengths between 35-220mm. Made of case-hardened steel, treated with Climadur high quality coating
FPS-E-8,0xL (EJOT)	Self-drilling screw, Ø8mm, lengths between 80-240mm and a cylindrical Torx T30 head. Made of stainless steel.
TKR 4.8 (EJOT)	Self-drilling screw, Ø4,8mm, lengths between 35-300mm and cabeza avellanada. Made of case-hardened steel, with CLIMADUR high quality coating

VHT-R 4.8 (EJOT)	Self-drilling screw, Ø4,8mm, lengths between 35-200mm y con cabeza avellanada. Made of case-hardened steel, with CLIMADUR high quality coating
FDD Plus 50 (EJOT)	Anclaje de cubierta plana, con taquillo de poliamida Ø8.0mm y clavo de zinc steel Zincado. Arandela de diámetro 50.0 mm. Longitudes desde 55 mm hasta 300mm
EFHD (EUROFAST)	Ricoh-point screw Ø6,3 mm, lengths between 60-400 mm with a Torx T-25 RSD bugle head. Made of carbonsteel with Magnisilver coated.
EDS-H (EUROFAST)	Sharp-25° screw Ø5 mm, lengths between 20-200 mm with a PH 2 bugle head. Made of carbonsteel with Magnisilver coated.
EDS-BZT/BGT (EUROFAST)	Self-drilling screw Ø4,8 mm, lengths between 60-300 mm with a HWH 8 mm head. Made of carbonsteel with Magnisilver coated.
EDS-BZTR/BGTR (EUROFAST)	Self-drilling screw Ø4,8 mm, lengths between 120-300 mm with a HWH 8 mm head. Made of carbonsteel with Zinc-plated coated.
GBS (EUROFAST)	Sharp-25° screw Ø6 mm, lengths between 60-200 mm with a Tx25 reduced bugle head. Made of carbonsteel with Magnisilver coated.
EDS B (EUROFAST)	Self-drilling screw Ø4,8 mm, lengths between 35-300 mm with a Tx25 reduced bugle head. Made of carbonsteel with Magnisilver coated.
EDS SRB (EUROFAST)	Self-drilling screw Ø4,8 mm, lengths between 60-300 mm with a Torx25 oval head. Made of carbonsteel with Magnisilver coated.
EDS S (EUROFAST)	Sharp-25° screw Ø4.8 mm, lengths between 30-300 mm with a PH 2 bugle head. Made of carbonsteel with Magnisilver coated.
DFCF (EUROFAST)	Nail point screw Ø6,7mm, length 32mm, with a HWH 8 mm head. Made of carbonsteel with Magnisilver coated.
ISPC-50 (EUROFAST)	S-point screw Ø8 mm, lengths L, with a trumpeted head. Made of polyamide PA6.
GBS A2 (EUROFAST)	Sharp-25° screw Ø8 mm, lengths between 65-190 mm with a Tx25 reduced bugle head. Made of RVS A2 passivated.

### Washers description

Washers	Characteristics
82 X 40 mm R (L.R ETANCO)	Reinforced steel plate 80x40mm, 1.0 mm thickness, with punched inside cone. Hole Ø 6mm. Aluzinc AZ 150 protection
82 X 40 mm R DF (L.R ETANCO)	Reinforced steel plate 82 x 40mm, 1.0 mm thickness, with punched inside cone. Hole Ø 5,1 mm. Aluzinc AZ 150 protection
82 X 40 mm R SC (LR ETANCO)	Reinforced steel plate 82 x 40mm, 1.0 mm thickness, with punched inside cone. Hole Ø 6,4 mm. Aluzinc AZ 150 protection
Etancoplast T 80x40 (LR.ETANCO)	Rectangular 80x40mm washer. Made of polyamide.
Etancoplast HP 82x40 (LR.ETANCO)	Rectangular 82x40mm washer, 2,45mm thickness. Made of polyamide.
IR 82 x 40 mm (SFS intec)	Steel plate with aluzinc protection, 82x40mm,1.0mm thickness
IRP 82 x 40 mm (SFS intec)	Steel plate with aluzinc protection, 82x40mm,1.0mm thickness
IF/GC 82 x 40 mm (SFS intec)	Steel plate with aluzinc protection, 82x40mm,1.0mm thickness
IG C 82 X 40 mm (SFS intec)	Steel plate with aluzinc protection, 82x40mm,1.0mm thickness
IRD 82 X 40 mm (SFS intec)	Steel plate with aluzinc protection, 82x40mm,1.0mm thickness
IRC/W 82X40 mm (SFS intec)	Steel plate with aluzinc protection, 82x40mm,1.0mm thickness
RP 45 (SFS intec)	Black circular Ø45mm sheath, lengths between 35-320mm. Made of polypropylene.
R 45 (SFS intec)	Black circular Ø45mm sheath, lengths between 35-320mm. Made of polypropylene.
DVP-EF 8240D (EUROFAST)	Aluzinc protection steel washer, 82x42 mm, 1.0mm thickness with an internal Ø4,85mm hole
DVP-EF/DF 8240 D (EUROFAST)	Aluzinc protection steel washer, 82x42 mm, 1.0mm thickness with an internal Ø4,85mm hole
DVP-EF 8040 D/N/H/XH (EUROFAST)	Aluzinc protection steel washer, 82x42 mm, 1.0mm thickness with an internal Ø4,85mm hole
VRF DVP-EF 50 10 ND (EUROFAST)	Aluzinc protection steel washer, 82x42 mm,1.0mm thickness with an internal Ø4,85mm hole
TLK-45 (EUROFAST)	Black circular Ø45mm washer, lengths between 35-320mm. Made of polypropylene.
TRP-45 (EJOT)	Blue circular Ø45mm washer, lengths between 35-320mm. Made of polyamide.
HTV 82/40 (EJOT)	Alu-zinc coated steel plate, 82x42 mm,1.0mm thickness with an internal Ø4,90mm hole
HTV 82/40 F (EJOT)	Alu-zinc coated steel plate, 82x42 mm,1.0mm thickness with an internal Ø4,90mm hole
EJOT HTK 2G 50 (EJOT)	Grey circular Ø50mm washer, lengths between 35-325mm. Made of polyamide.
SP(A)-8240 (GUARDIAN)	Senzmir steel washer, 82x42 mm,0,7/0,75/1.0mm thickness
TB(P) 8040 (GUARDIAN)	Blue rectangular 80x40mm washer, 5,00mm thickness. Made of modified polyamide.
GUARDIAN WELD 80 PVC (GUARDIAN)	Steel induction washer Ø 80mm,0,7/0,75/1.0mm thickness
ZLVT0001 (ZAHN)	Alu-zinc coated steel plate, 82x42mm,1.0mm thickness
ZLVT0012 (ZAHN)	Alu-zinc coated steel plate, 82x40mm,1.0mm thickness
RHINOBOND PVC PLATE (OMG)	Steel induction washer Ø 80mm,0,7/0,75/1.0mm thickness